

Technical data

Spindle Type BT50
Spindle Speed 6000 rpm (Belt Type)

Spindle Motor 18.5/22 kw (22/26 kw)
Tool Changer 24/32T Arm Type (50T Optional)

Servo Motor X: 38 N.m Y: 27 N.m Z: 27 N.m
Control System SIEMENS 828D / FANUC 0iMF plus
Balancing System Nitrogen Balance
Ball Screw X: 6312 Y: 5010 Z: 5010
Linear Guides X: 2*55mm Y: 2*55mm Z: Box Guide
Number of Wagon X: 10 Y: 4 Z: Box Guide
Rapid (mm/min) X: 15000 Y: 15000 Z: 10000

Traverse (mm) X: 2500 Y: 1650 Z: 800
 X: 3000 Y: 1900 Z: 1000

Spindle to Worktable 120~1050 mm / 120~1120 mm

Table Size (mm) 1300*2500 / 1800*3000

Gate Width 1600 mm / 1600 mm

Maximum Load 4500 kg / 5000kg

Machine Weight 20000 kg / 28000kg

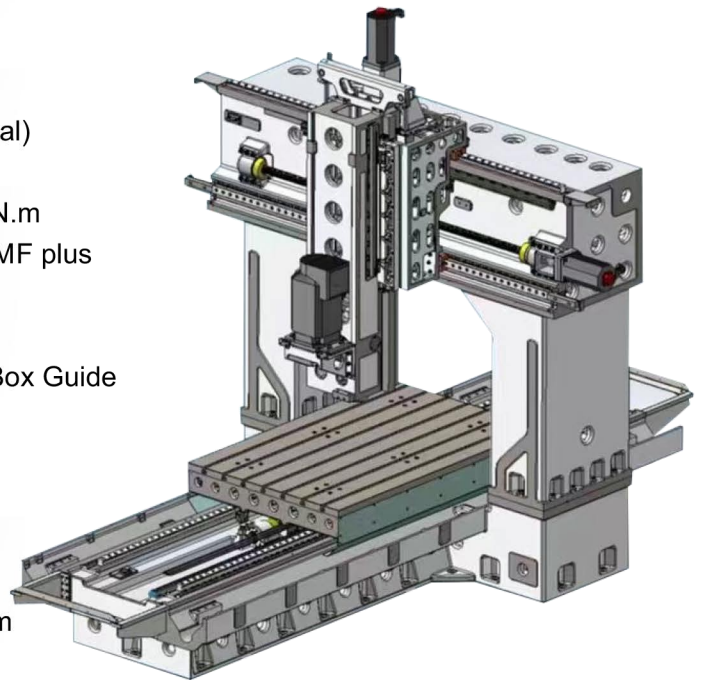

Dimension (L*W*H) 6700*3730*3900